

# ITEM CODE : CH1515

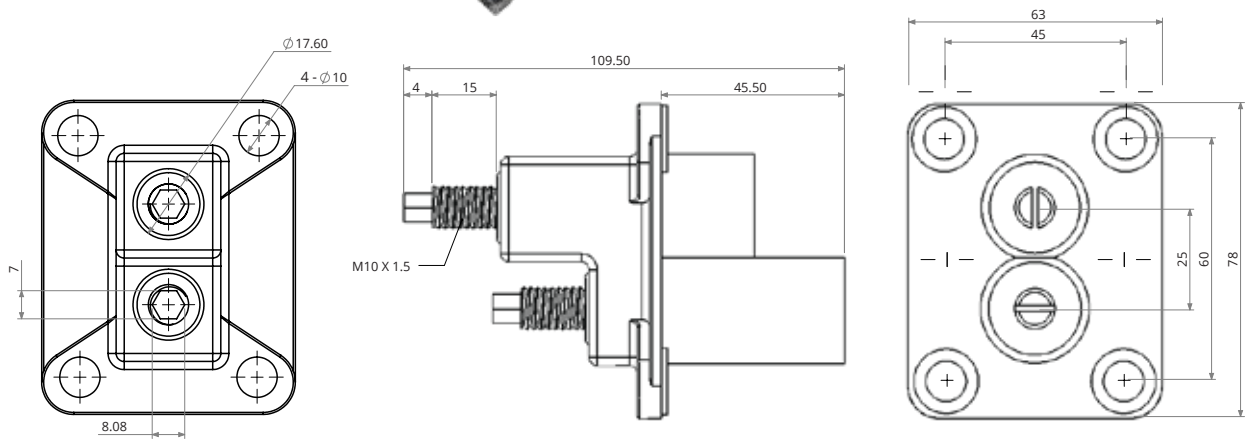

## JUMP START RECEPTACLE

Heavy duty, high capacity jump-start connectors for vehicles and equipment. Ideal for use where access to terminals is restricted or dangerous. Eliminates the chance of cross polarity connections through the specially shaped plug. Reduces chance of sparking and possible ignition of flammable materials.

Features high impact ABS plastic housing/insulator. Zinc coated terminals. Easy to mount and connect, supplied with washers and M10 Nyloc Nuts.

## TECHNICAL INFORMATION:

- \* Removes risk of terminal crossing
- \* High Impact ABS Plastic
- \* Zinc Coated Terminals

## **SPECIFICATION / FEATURES:**

Protective Cover: CA1533 (HJUMPSTART-C)

Material: Polybutylene Terephthalate Thermoplastic Polyester

Thread and Pitch Size: M10 X 1.5 (10mm X 1.5mm)

Nut, Lock washer and Washer: M10 Stainless Steel Size

## **MOUNTING BRACKET:**

- \* BR1097 Jumpstart Receptacle Bracket
- \* BR1250 Isolator Jumpstart Receptacle Combi.
- \* BR1254 Step Jumpstart Isolation Straight
- \* BR1268 Jumpstart Receptacle Bracket
- \* BR1272 Jumpstart Receptacle Bracket
- \* BR1289 Isolation Station Bracket
- \* BR1294 Jumpstart Receptacle Bracket
- \* BR1300 Jumpstart Isolation Angled
- \* BR1301 Jump Start Isolation Station Straight
- \* BR1302 Isolation Station Bracket
- \* BR1313 Jumpstart Receptacle Bracket
- \* BR1350 Jumpstart Isolator Bracket
- \* BR1356 Isolation Station Bracket Build
- \* BR1365 Isolation Bracket
- \* HME-3306030413-01 Jumpstart Isolation Assembly