

DIMENSIONS

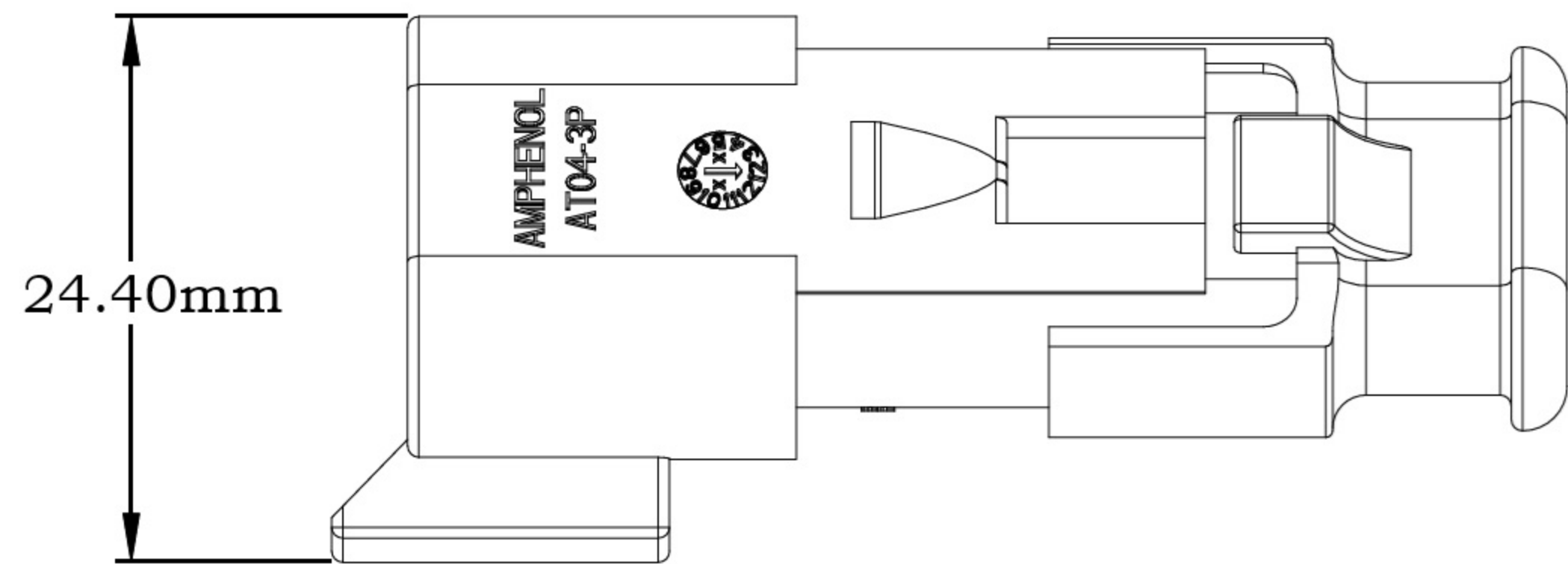

PART NUMBER CHART	
COLOR	PART NUMBER
GREY	AT04-3P-SR02GRY

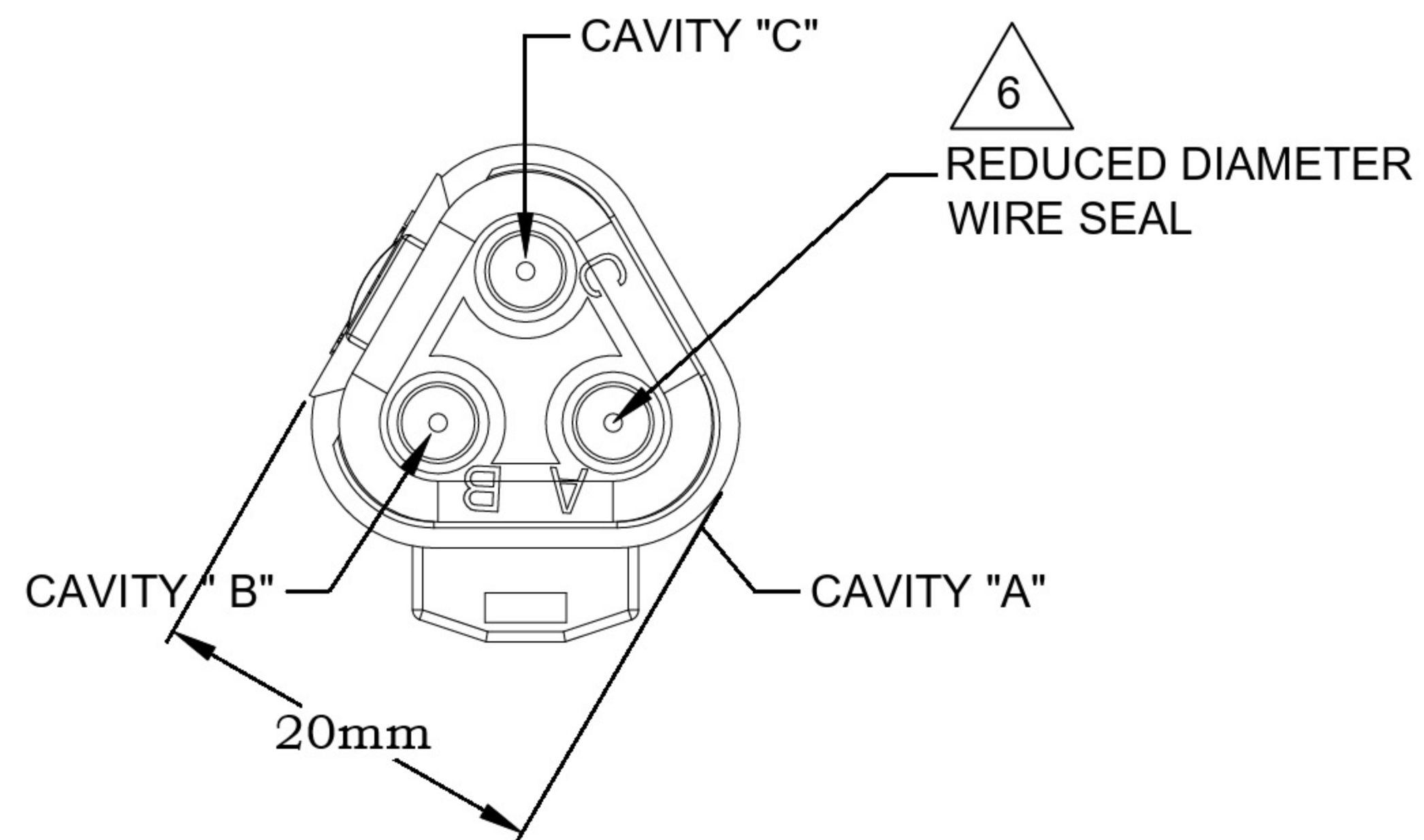
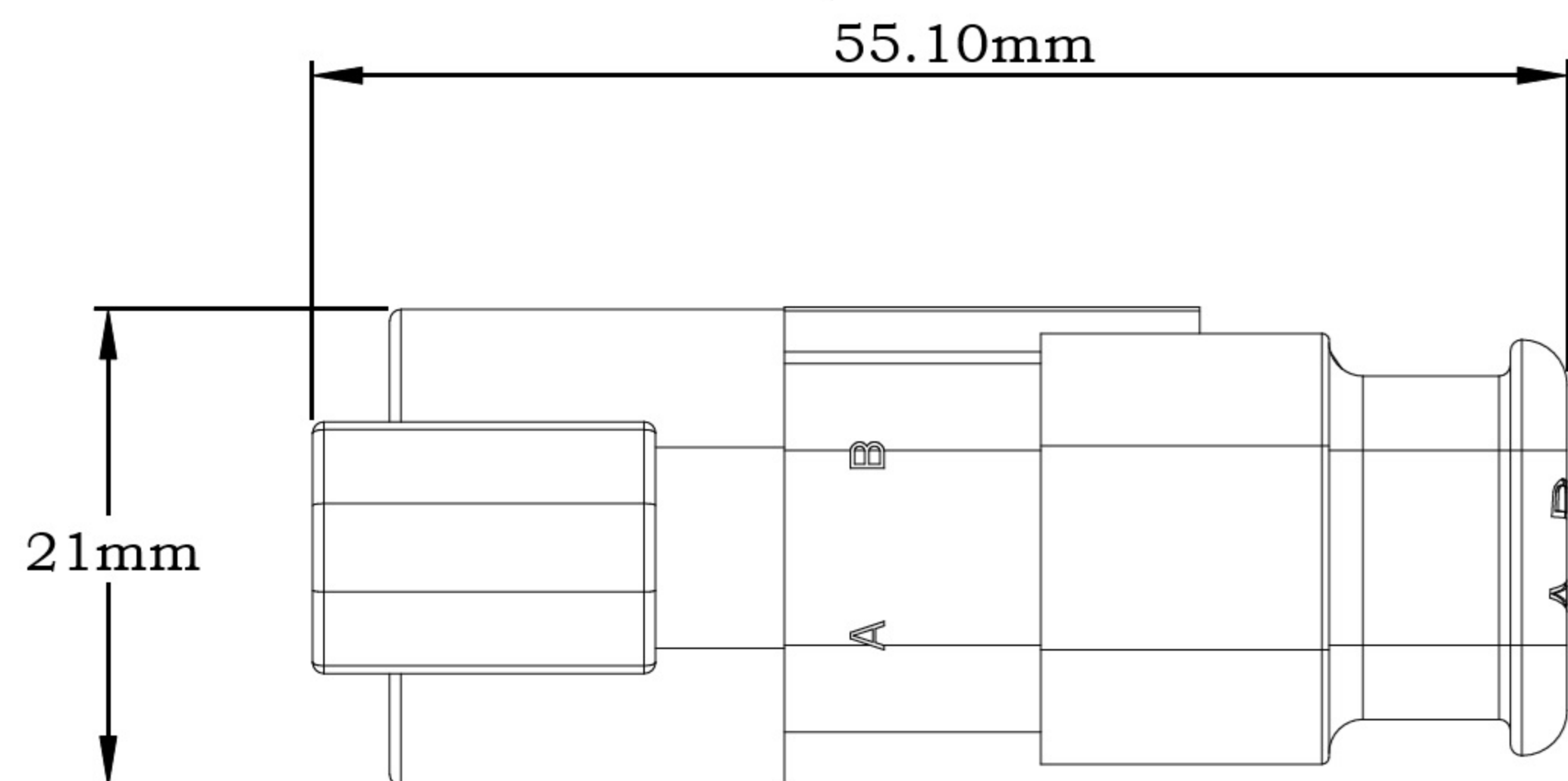

REQUIRES CONTACT RETENTION WEDGE AW3P

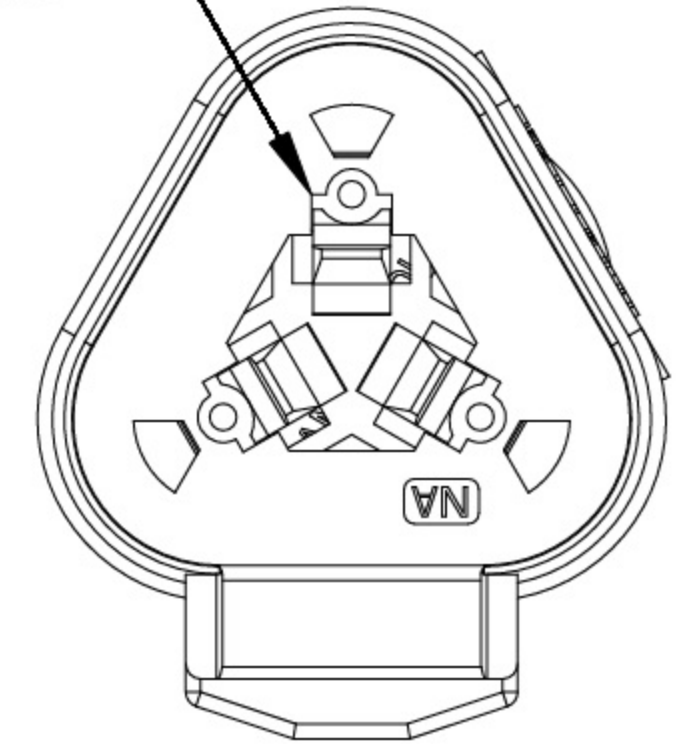

STRAIN RELIEF END CAP - BLACK - ALL CONNECTORS

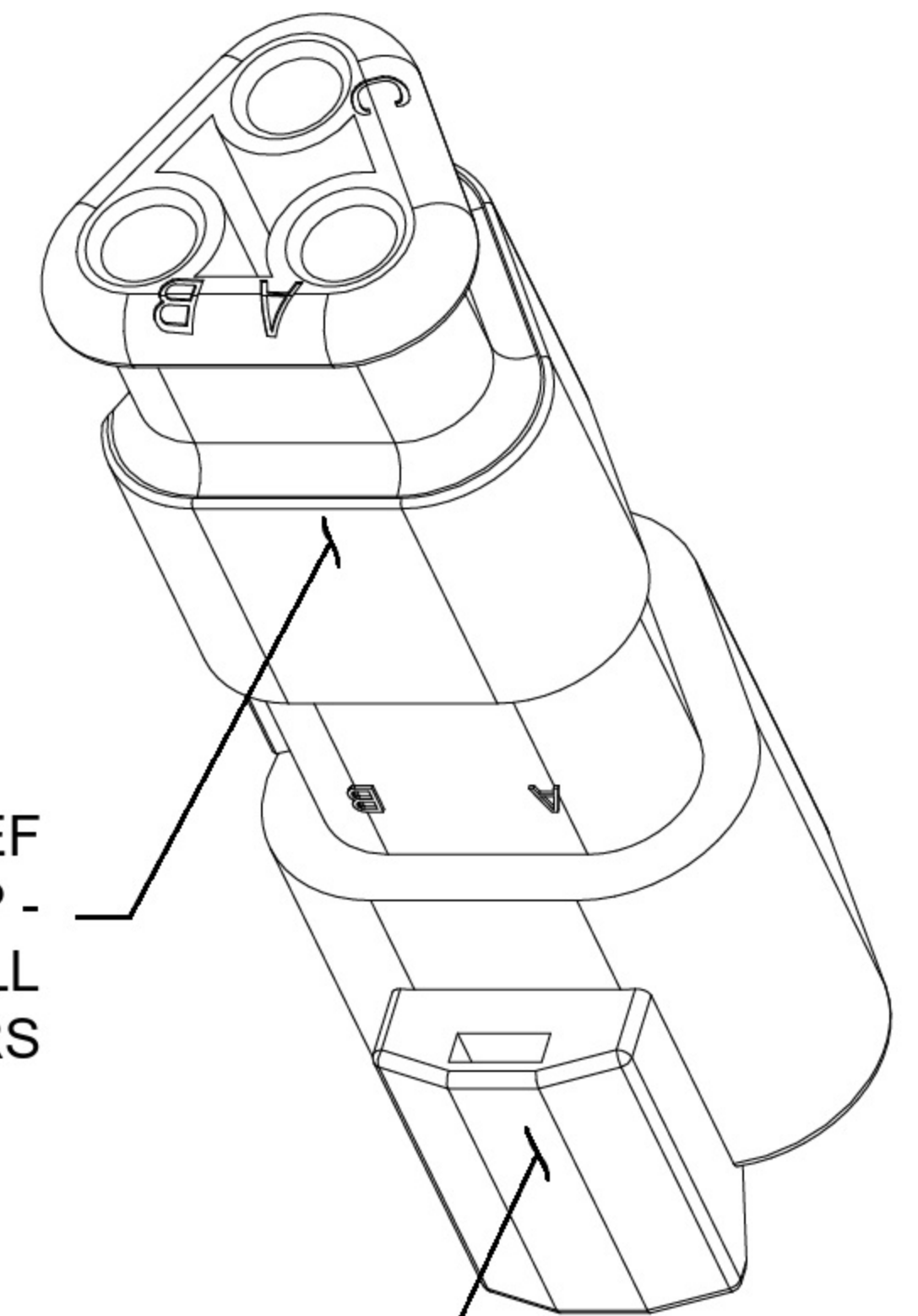

REFER TO PART NUMBER CHART FOR AVAILABLE CONNECTOR COLORS

6 CONTACT SIZE AND REAR SEAL WIRE RANGE:

CONTACT SIZE	MIN. INSUL O.D.	MAX. INSUL O.D.	TYPICAL WIRE RANGE
16	1.35 mm (.053 in)	3.05 mm (.120 in)	14 - 20 AWG (2.0-0.5mm ²)