

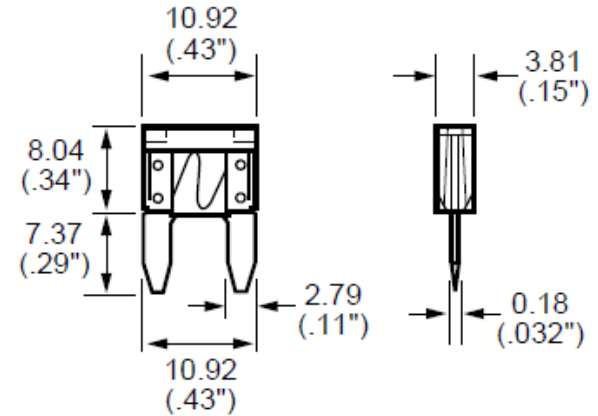

Reference Dimensions



AMPERAGE RATING :	20 AMPS
TYPE :	MINI BLADE
MATERIAL:	HOUSING : NYLON TERMINAL: SILVER PLATED ZINC ALLOY
BODY COLOR:	YELLOW
VOLTAGE RATING :	32VDC
INTERRUPTING RATING:	1000A @32VDC
DESIGN STANDARDS:	: U.L. Standard for Automotive Blade Type Fuses. SAE (Society of Automotive Engineers) J1284.

ELECTRICAL CHARACTERISTICS:

% of Ampere Rating	Opening Time
110%	100 Hours Minimum
135%	.75 sec., Min. ; 600 sec., Max.
200%	.15 sec., Min. ; 5 sec., Max.
350%	.080 sec., Min. ; .250 sec., Max.
600%	.030 sec., Min. ; .100 sec., Max.