

Note: Use ES1-20mm for Black Wires and ES1-30mm for other wire color (Shrink Tube)

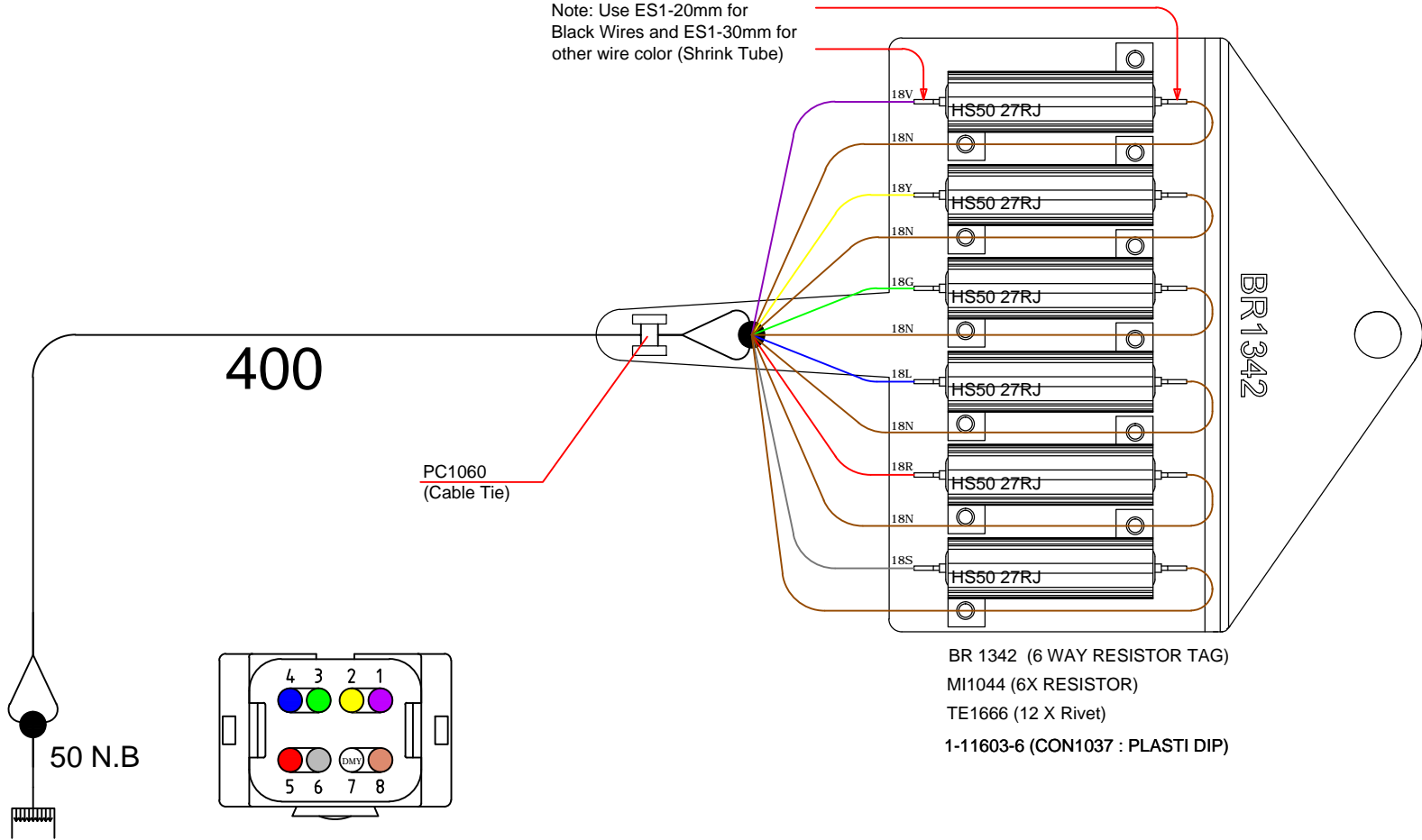

- BR 1342 (6 WAY RESISTOR TAG)
- MI1044 (6X RESISTOR)
- TE1666 (12 X Rivet)
- 1-11603-6 (CON1037 : PLASTI DIP)

P/N	DT04-8PA-E005			
PIN	SIZE	CLR	MARK	CUTTING LENGTH
1	18	V		
2	18	Y		
3	18	G		
4	18	L		
5	18	R		
6	18	S		
7	DMY			
8	16	N		



HARNESS P/N	HME-2601090513-01			
HARNESS NAME	6 WAY HS50 RESISTOR PACK			
DATE	XXX			
JOB NUMBER	XXXXXX			
BRAID COLOR	BLACK BRAID			
WIRE SPECS	BOOT SPEC	XLPE 125	BUSSED DEG WIRE	NO SOLDERED RECEPTACLES JOINTS
TICK IF APPLICABLE	<input checked="" type="checkbox"/>	<input type="checkbox"/>	<input checked="" type="checkbox"/>	<input type="checkbox"/>

NOTE : WHERE A BOOT IS NOT USED THE LENGTH OF EXPOSED WIRE BETWEEN THE BACK EDGE OF THE CONNECTOR AND END OF BRAID / TUBING WILL BE 50mm FOR A 1 OR 2 WAY CONNECTOR + 2mm PER WAY / LOCATION FOR CONNECTORS OF MORE THAN 2 WAY.

NOTE : ALL MEASUREMENTS ARE TO THE BACK EDGE OF THE CONNECTOR HOUSING (WHERE THE WIRES GO IN)